

VII. Specifications

Transmitter

Power requirements:	
120VAC @ 60 Watts - pulsing @ 15 Watts - normal	A.C. protected with 1/2-Amp, slo-blow, and panel mounted fuse.
12VDC @ 10 Watts-pulsing @ 0.5 Watts - normal	12VDC inputs protected with circuit board mounted 4-Amp fuse.
Output voltage	2300-2500VDC typical, across 10-megohm load. 50VDC typical, across 625-ohm load.
Output pulse rate	One pulse every 3 to 4 seconds.
Output pulse duration	Approximately 200 milliseconds, typical.
Fault Impedance Indicator	This indicator not intended to give an accurate representation of fault impedance. It does, however, give an "idea" of what the fault impedance is.

Detector (Galvanometer)

9VDC, transistor battery powered	Battery test feature shows if battery is good on detector meter. Battery easily user-replaceable.
Taut-band, zero-center 3½" meter	Large, quick-response meter guides user to cable fault quickly.
Meter sensitivity & balance adjustments	Allows user to fine-tune operation of Detector.

Dimensions

9" H x 18" W x 8" D

Weight

18 lbs. net
21 lbs. shipping

VI. Parts List

HJA-470	The Pinpointer complete.
HJA-470-109	Optional Rechargeable Battery Kit. Includes 12-volt D.C., 7.0-AH rechargeable battery, recharger unit, cables, mounting bracket and hardware.
470-100	Detector unit, complete. Includes 9-volt battery.
470-101-HDPR	Detector probe, red.
470-101 -HDPB	Detector probe, black.
470-101-HDE	Detector probe extender, red.
470-101-HDE	Detector probe extender, black.
470-102	Transmitter module. Includes power and high-voltage cables.
470-206	Transmitter ground probe.
470-104	12VDC battery cable.
470-105	120VAC adapter cord.
470-106	Equipment carrying case, with labels and Detector bracket.
470-100-MAN	Pinpointer Operations Manual.
470-208-A	12-volt D.C., 7.0-AH rechargeable battery.
470-209-B	12-volt battery Recharger unit, complete.

IMPORTANT NOTE: The Pinpointer Transmitter and Detector have no user-serviceable parts inside, except as outlined in this manual. Please return the complete Pinpointer to H.J. Arnett LLC. or qualified personnel when service is required.

V. Troubleshooting

PROBLEM	PROBABLE CAUSE	REMEDY
<i>Transmitter unit will not pulse with HI VOLT OUTPUT switch ON.</i>	<ol style="list-style-type: none"> 1) Blown 1/2-Amp panel fuse. 2) Transmitter not connected to power source. 	<ol style="list-style-type: none"> 1) Replace fuse. 2) Plug unit into 120VAC outlet. If this does not work, try powering the unit with an external 12VDC battery. This can get you through a job until the 120VAC part of unit can be serviced.
<i>Transmitter will not pulse when using a 12-volt external power source.</i>	<ol style="list-style-type: none"> 1) Blown 4-Amp circuit board fuse. 2) Bad 12VDC battery cable. 3) Low charge on battery. 	<ol style="list-style-type: none"> 1) Replace fuse on circuit board. 2) Do continuity checks on the battery cable. 3) Check battery voltage. 4) Try powering unit with 120VAC. This can get you through a job until the 12VDC part of unit can be serviced.
<i>Fault Impedance Indicator will not pulse to the "short" LED indicator with Transmitter output leads shorted.</i>	<ol style="list-style-type: none"> 1) Calibration pot incorrectly adjusted. 2) Broken or resistive transmitter output cables. 3) Problem in unit 120VAC power supply. 	<ol style="list-style-type: none"> 1) Turn calibration pot clockwise until pulse makes "SHORT" LED come on. 2) Do continuity checks on output cables. 3) Try powering unit from a 12VDC source.
<i>Pinpointer Detector unit will not come on or register pulses correctly with the Balance Control / ON-OFF switch pulled out to the ON position.</i>	<ol style="list-style-type: none"> 1) Dead 9 volt battery. 2) Broken Detector probe cables. 3) Dirty banana jacks on Detector. 4) Operator in area of undetectable pulses. 5) Operator not oriented correctly to probe color. 6) Sensitivity turned too low on Detector. 7) Balance control improperly adjusted. 	<ol style="list-style-type: none"> 1) Press battery test button on back of Detector. if meter does not deflect to "Battery OK" then replace battery. 2) Do cable continuity checks. 3) Clean jacks. 4) Refer to Manual, section II.E. 5) Refer to Manual, section II.E. 6) Increase sensitivity setting. 7) Meter needle should be centered on scale when Transmitter not pulsing. Refer to Manual, section II.E.

IV. Optional Rechargeable 12-Volt Battery Kit Instructions

A. Charging the Rechargeable Battery

It is a good idea to charge the battery before initial use with The Pinpointer. To charge the battery:

- 1) Disconnect any cables from the battery.
- 2) Connect the red and black leads from the battery charger to the battery. Pay strict attention to the colors: always connect red to red and black to black.
- 3) The battery charger is fully automatic. The bi-color LED will let you know the condition of the battery if the LED is red AC is connected and battery is fast charging. If the LED is green then AC is connected and battery is fully charged.
- 4) The battery will recharge overnight if slightly discharged, or within 24 hours if very discharged. When the charging cycle is complete, the green LED will be on.
- 5) Caution: If the LED remains red for more than 24 hours, unplug the charger from AC power and check the battery. There may be a problem with the battery.

B. Notes

Normally the battery will last through one job. When coming in from a job, plug the battery into the charger for an overnight recharge. This assures a charged battery for the next job.

The battery can be left on the charger for up to 48 hours. Additional time will not result in additional charge so the charger should be disconnected after 48 hours. The charger limits charging current, however, the battery is never overcharged.

The battery is fully charged when its terminal voltage has reached 13.3 to 13.4 volts. It should be recharged when the terminal voltage drops below 11.5 volts.

A new battery has an Ah rating of 7.0 Amp-hours.

III. Theory of Operations

If a D.C. pulse is transmitted down a faulted, unshielded cable, and if the voltage is high enough to break through the aluminum hydroxide (white powder) formed at the fault, it will go to earth ground at the point of the fault. The current pulse wants to return to the Transmitter ground. To do this it radiates out in all directions. Some of the current starts back immediately, while some of it goes forward a short distance before returning.

To get this picture firmly in your mind, try to recall a simple physics experiment you most likely performed in high school, where a bar magnet was placed under a piece of paper, and iron filings were sprinkled on the paper over the magnet. The filings fell into place along the magnetic lines of flux which are similar to the voltage lines of the Pinpointer pulse. Think of the fault as the north pole and the Transmitter ground as the south pole (as shown in figure 11, below).

If a sensitive D.C. galvanometer is used to probe the earth “football chain” fashion along these lines of force, an increasing indication will be observed at the two points of voltage concentration, the Transmitter ground and the fault. A null at the fault is observed when the fault is exactly halfway between the probes. This is due to equal amounts of current entering the probes going in opposite directions and cancelling each other at the galvanometer.

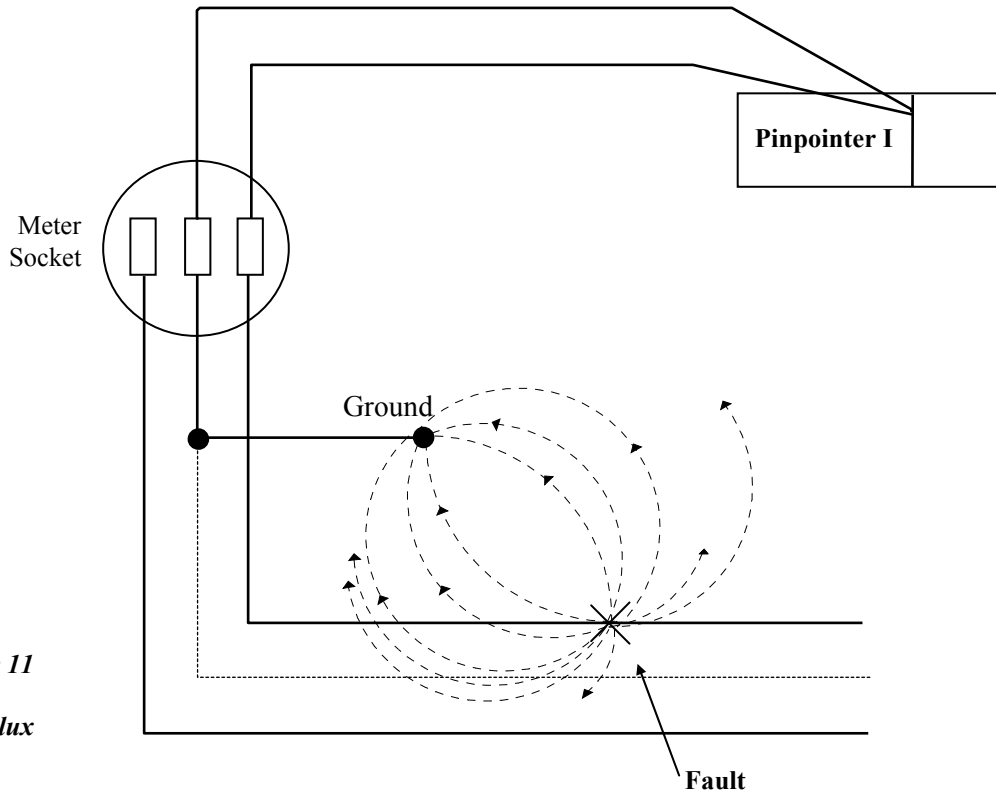

Figure 11
Lines of Flux

G. Locating a Fault at the Riser

As previously mentioned, if the Detector pulses to the right when first activated the fault may be at the base of or in the riser itself. Because the riser is against the house a different technique is required to confirm the fault. Proceed as follows:

1. Even though you suspect a fault at the riser, check along the route of the cable in the usual manner. The location of your Transmitter ground may have given you an improper indication.
2. If you still have doubts, connect the Pinpointer to the far end of the cable and check for indication at the riser.
3. Refer to Figure 10, below. Turn probes at an angle to the house and check for a null reading along an imaginary line of thrust as shown. Be sure to take two readings. A null reading across a line pointed at the riser will indicate a fault at the base of or in the riser.

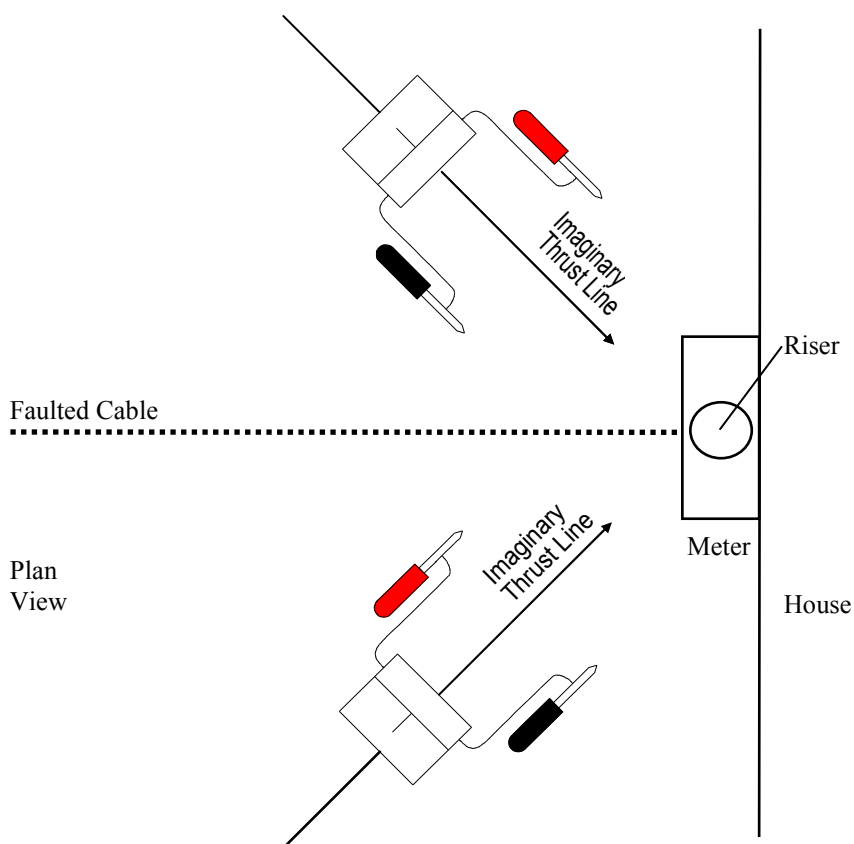

Figure 10
Locating a Fault at Meter Riser

Light up a cigar. You are now a hero - where the two null marks intersect is the cable fault! (See figures 8 and 9, below.)

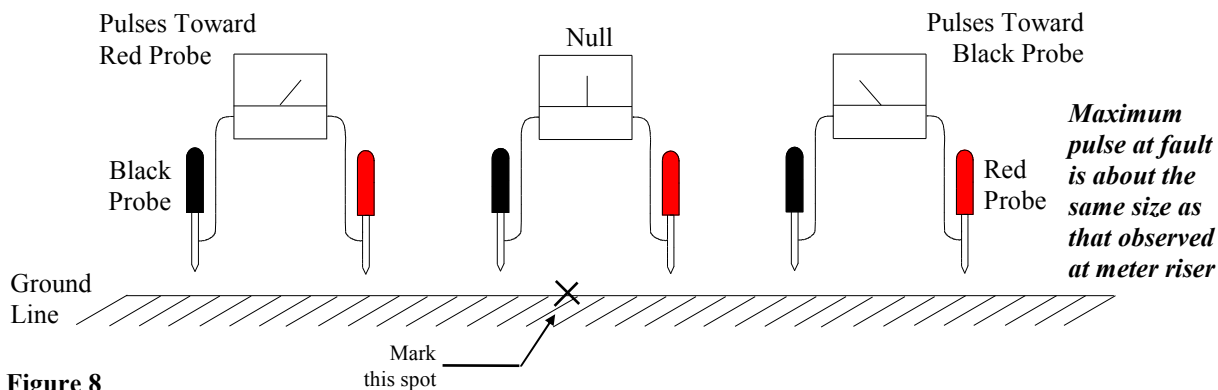

Figure 8

Meter Deflection To Transformer From Meter

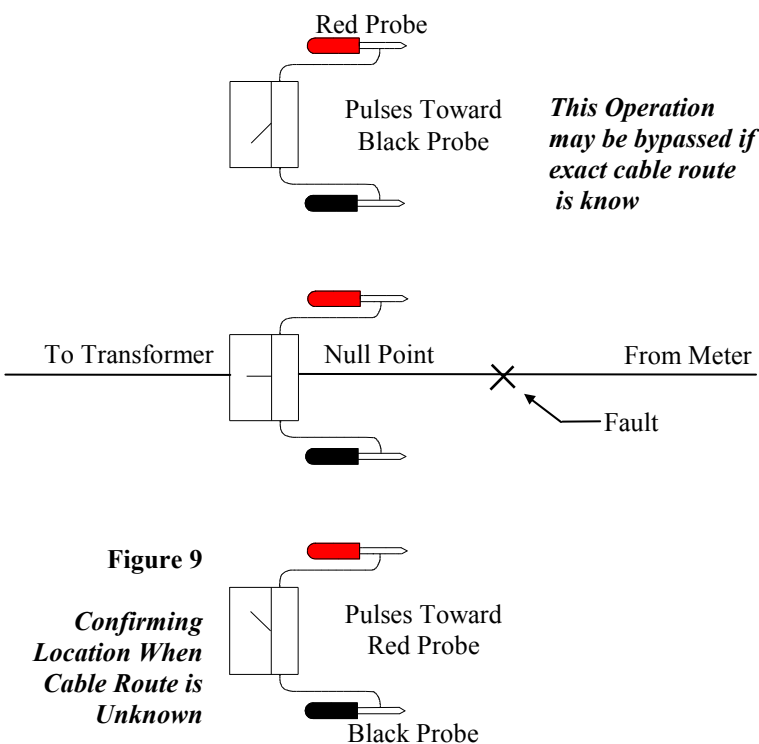

Figure 9
Confirming Location When Cable Route is Unknown

Detector Usage Tips

1. Remove hand from probe after inserting it into the ground, as it disturbs the Detector meter.
2. In rocky or frozen ground, on cement or blacktop, or in any area where it is too hard to insert the probes, we suggest the following:
 - a. Gather 2 rectangular sponges, a plastic bucket, and a bag of rock salt. Dissolve approximately 2 cups of rock salt in ¾- full bucket of water. Soak the sponges thoroughly. Stick the Detector probes through the sponges so they can lay flat on the ground and proceed as usual. Resoak the sponges often.
 - b. If wet sponges are not available, try using copper or aluminum plates, about 4x8 inches in size Drill holes in the plates to accept the tips of the probes. The plate is not as good as the sponge, but either method works well when needed.

E. Detector Connections

Remove the Detector from its bracket in the Pinpointer case. Pull out on the balance control knob to power up the Detector. With the sensitivity control at its lowest setting, adjust the balance control until the meter needle is centered on the scale (see figure 5 for reference). Plug the red and black Detector probe cables into their respective jacks at the rear of the Detector unit. ***Note that it is important to keep these banana jacks clean for maximum Detector sensitivity!***

With your right hand, push the red probe into the ground near the meter riser, your ground stake, or wherever you have established your local ground. Insert the black probe to your left, about 5 feet away down the route of the faulted cable. You should now be standing between the probes with the red probe to your right (toward the Transmitter) and the black probe on the left. *To locate the fault you must always maintain this orientation -- your red probe/right shoulder toward the Transmitter, and your black probe/left shoulder down the cable route.* This is because the Pinpointer puts out a negative pulse, and the Detector meter is wired to pulse to the left toward the fault. If the needle pulses to the right, the fault may be behind you, near or in the meter riser. See section G, page 13 for special instructions in this case.

While you are close to the meter riser or the location of your established ground the Detector will show each Transmitter pulse. Adjust the sensitivity knob to give a clear reading, ***but use as little sensitivity as possible.***

Soon after moving away from the ground you will most likely lose the pulse on the Detector. *This is normal!* This is the “silent detector” feature that keeps you from locating phantom or ghost faults. Whenever the Detector starts pulsing again you are approaching a real fault.

F. Locating the Fault

Proceed down the route of the cable “football chain” fashion, taking readings every 20 to 30 feet. ***Do not cross probes*** – the black probe should remain in front, to your left, and the red to your right. As previously mentioned, you will observe readings (pulses) at the Transmitter ground, but as you leave that area and move down the cable they will drop to or near zero until you reach the vicinity of the actual fault.

Note: *You will notice that as you insert the probes into the ground, the needle will hold to one side of the meter for a few seconds. This is a capacitive charge that will quickly dissipate and the meter will return to zero.*

As you close in on the area of the fault you will observe steadily increasing pulses toward the black probe. As you continue the readings will suddenly reverse, and pulses will deflect to the right. Bring the probes closer together so that they are about 2 or 3 feet apart. Again follow the direction that the Detector needle is pulsing until you observe a null reading (no deflections). Mark the spot exactly halfway between the two probes. If the exact route of the cable is not known, turn the probes 90° and repeat the process, watching as before for needle deflections until another null reading is observed.

different locations and repeat the locating procedure. Note that this setup is always necessary when locating a fault on a primary cable.

2. *Disconnect energized cables.* Disconnect the faulted cable from the transformer if the voltage on the cable is 80 volts or more. Especially in cases where the fault is high impedance and is buried in very dry soil or in conduit under pavement, the reduced voltage on the cable may be too much for the pulse to push against. Again, the thought here is to isolate the cable from as many external influences as possible, so remember to isolate, isolate, isolate!
3. *Transmitter from the other end of the cable.* Go to the far end of the cable, connect the Transmitter, and repeat the entire process from that end.

The emphasis here is that successful fault locating depends on establishing a good, correct local ground. Most of the time connecting onto the neutral does the job. But when a high-impedance fault is located in high dielectric soil (dry and sandy), is under cement or asphalt, or is in an area crowded with bare conductors, pipes and grounds, all other grounds must be removed from the faulted cable. This ensures that the local ground you establish with the probe is the shortest, lowest impedance return path for the Transmitter's pulse. **The Pinpointer will always locate the fault with the proper ground.**

When more than one customer is served on the same cable from the transformer, connect the Pinpointer to the first meter past the fault. Pull all other meters, if any, past the fault, as shown below in figure 7.

After these connections are made, turn on the high-voltage output on the Transmitter. The unit will begin to emit a 2500-volt pulse every 3 to 4 seconds.

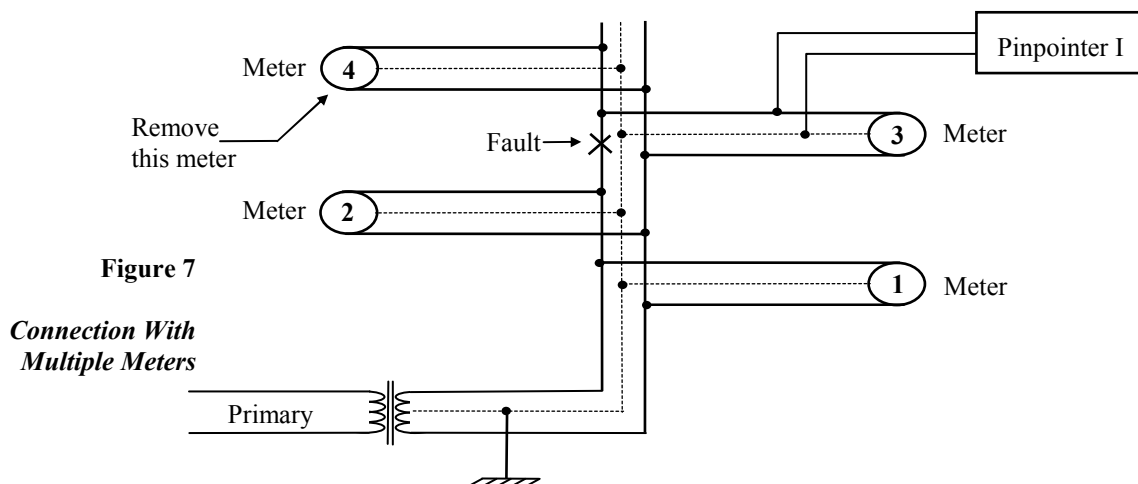
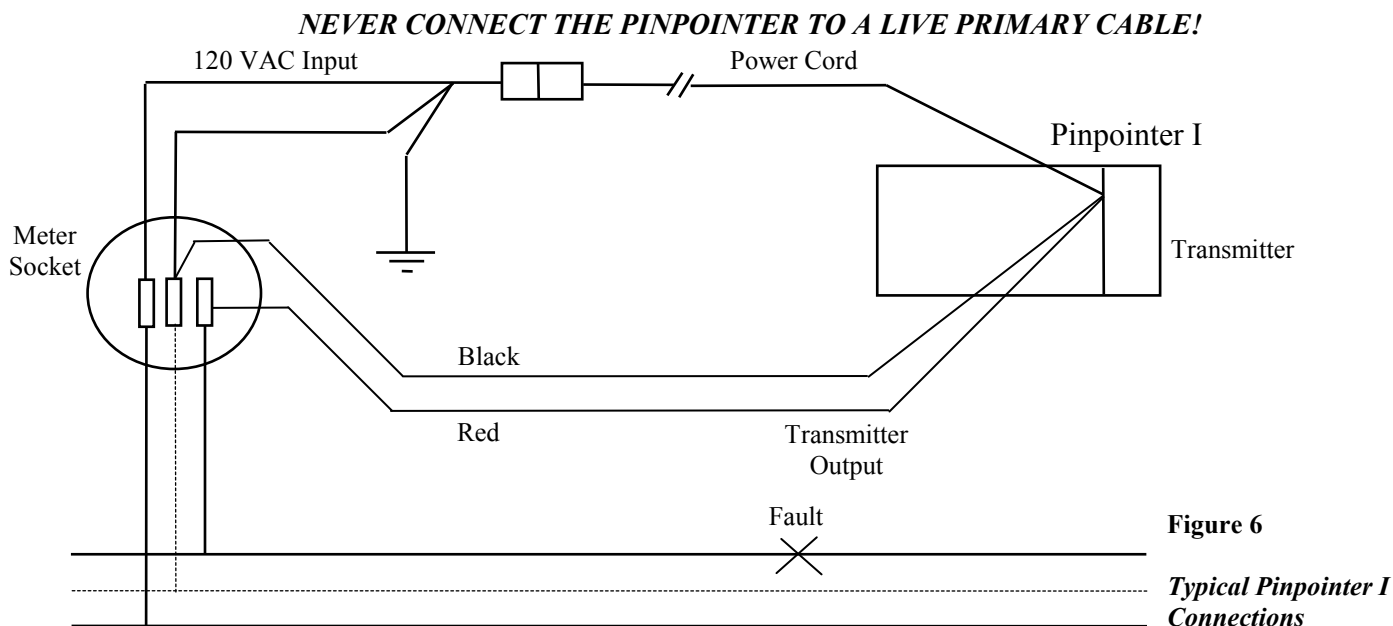

Figure 7
Connection With Multiple Meters

The Pinpointer is in effect a 2500-volt Megger, which will indicate the impedance of the cable fault. This feature will tell you instantly if the cable is good or bad, as the indicator will not pulse when it is connected to a good cable. It will also tell you that the Transmitter is working properly, and whether or not there is voltage on a faulted cable - halfway up the scale is about 120 volts. Turn the Transmitter off.

D. Connecting to Faulted Cable and Ground

Now connect the red Transmitter output cable to the faulted cable at the house meter (see figure 6, below). Note that it is generally not necessary to disconnect the faulted cable from the transformer except in cases explained below. Voltage on a faulted secondary cable (90 volts or less) will not harm the Pinpointer.



The next step is simple but very important -- success depends on the correctness of this connection. Clip the Transmitter ground cable (black) to ground at the meter box. In 95% of all cases this is all that is required to establish the proper ground, but sometimes special techniques are needed. If you are unable to locate the fault, try the following:

1. **Establish your own ground.** Remove neutral from system ground at both ends, especially if neutral is bare copper. Disconnect any temporary service to house. Push the ground probe provided with the Pinpointer into the ground at a right angle to and as far away as possible from the faulted cable. The black Transmitter ground cable is 12' in length and should provide enough distance from the faulted cable to be effective. Connect this cable to the ground probe. If this procedure does not help locate the fault, try moving the ground probe to

II. Operation

A. General

Locating cable faults with the Pinpointer is simple. With the proper setup, and most importantly, with the proper connection to ground, the Pinpointer will work every Time.

The Pinpointer is specially designed to eliminate or reduce false readings from “Phantom” or “ghost” faults. This design allows the Detector meter to remain “silent” And not pulse until it is in the near vicinity of the fault. The needle will then show Pulses with increasing strength, directing the user quickly to the fault.

All secondary cable faults that are detectable by the earth gradient method can be Found using the Pinpointer, assuming proper connections are made by the operator. This is due to the high-voltage (2500VDC) pulse emitted by the Transmitter which Burns to ground any secondary cable fault. The Transmitter then adjusts its output According to the resistance of the fault, down to approximately 50VDC.

B. Transmitter Connections

***IMPORTANT: ALWAYS WEAR RUBBER GLOVES
WHEN OPERATING THE PINPOINTER!***

Whenever possible it is best to start at the house meter. With the Transmitter power Switch OFF, connect the Pinpointer to a 120-volt A.C., 60Hz source, usually at the Meter. When using the 120VAC adapter cord, *always* connect the wire with green Insulator to system ground. Either the black or white wire may be clipped to the hot Leg. Connect the other to neutral.

If A.C. power is not available, connect the Pinpointer to a 12-volt D.C. external power Source. Every Pinpointer is supplied with a 12VDC battery cable for connection to a Truck battery. When the optional rechargeable battery is ordered, a cable is supplied for connecting the battery to the 12VDC inputs. *Always observe proper polarity!*

C. Calibrating the Fault Impedance Indicator

The second step is to calibrate the fault impedance indicator. This step is not necessary if you are not interested in knowing the approximate impedance of the fault. Note that if there is voltage on the faulted cable, learning true impedance is not possible.

To calibrate, short the red and black Transmitter output cables by clipping them together. Turn on the Transmitter and adjust the potentiometer on the front panel (labeled “Set full scale - output shorted”) so that the fault resistance indicator pulses to the “SHORT” LED indicator for each Transmitter pulse.

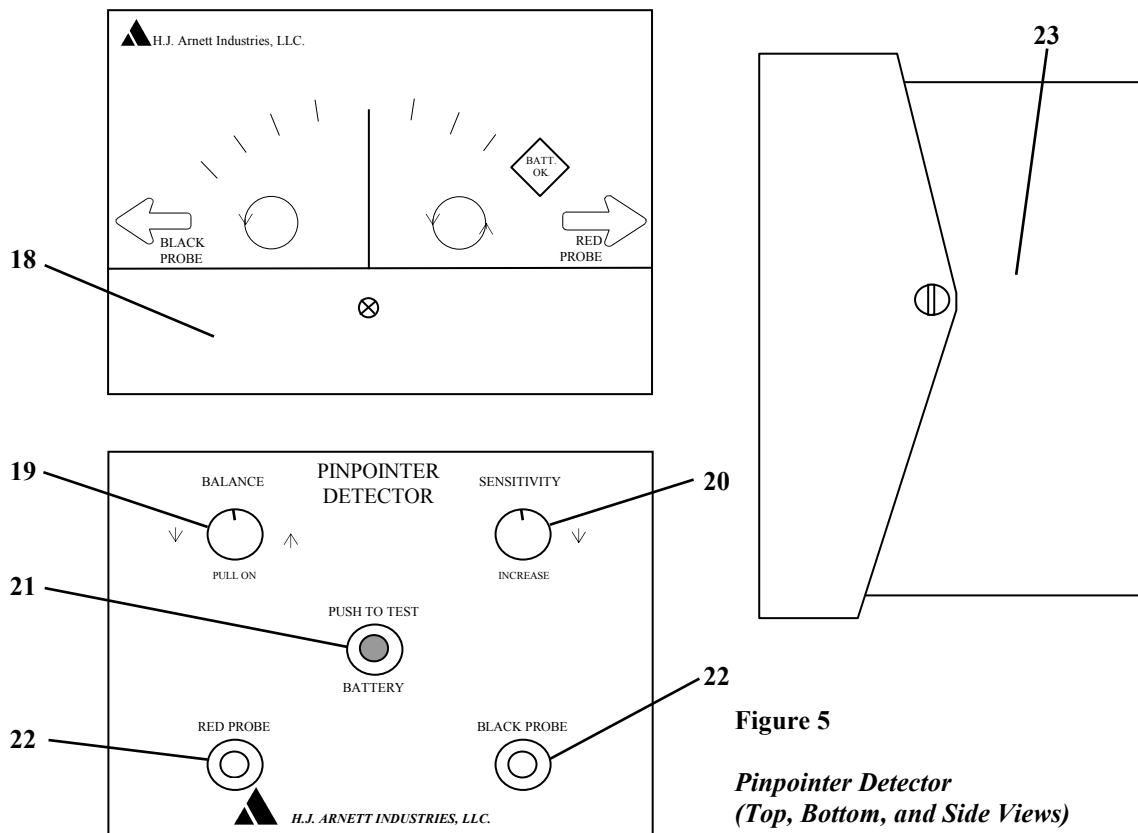
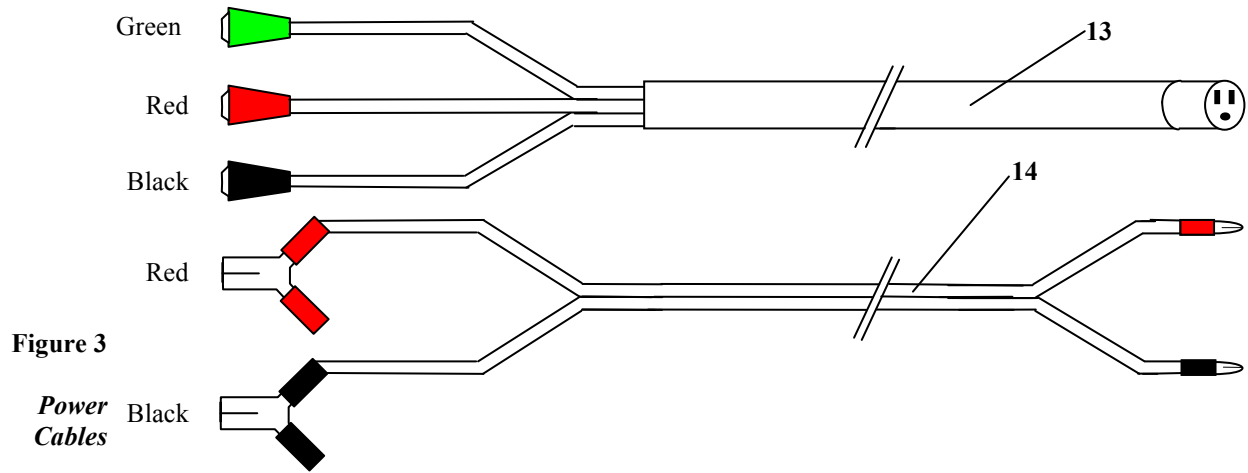

Figure 5
*Pinpointer Detector
(Top, Bottom, and Side Views)*

18. Top view of large 3½" zero-centered, quick-response D.C. Micro-ammeter. Fault is located by watching needle deflections To the left and right. Also shows battery test.
19. Balance control/pull on-push off switch. Used to power up the Detector and zero-balance the meter.
20. Sensitivity control. Best results are obtained when sensitivity Is at lowest setting needed to display Transmitter pulses Satisfactorily.
21. Battery test switch. When pressed, needle on meter will Indicate if battery output is o.k.
22. Red & black Detector probe cable input terminals.
23. Side view of Detector housing. Removal of screws on each Side separates the halves of the housing, allowing access to The 9-volt battery. *Not shown: neck strap, which is secured to The housing by these screws.*

**Note: Figures 2 through 5 not drawn to scale
Not shown is the tray, which holds the cables and probes.**



- 13. 3-foot A.C. adapter cord. Used to make 120VAC power connection at meter base or at transformer.
- 14. 12-foot, 12VDC battery cable. Used *only* to connect external 12-volt battery source - not for 120-volt use!

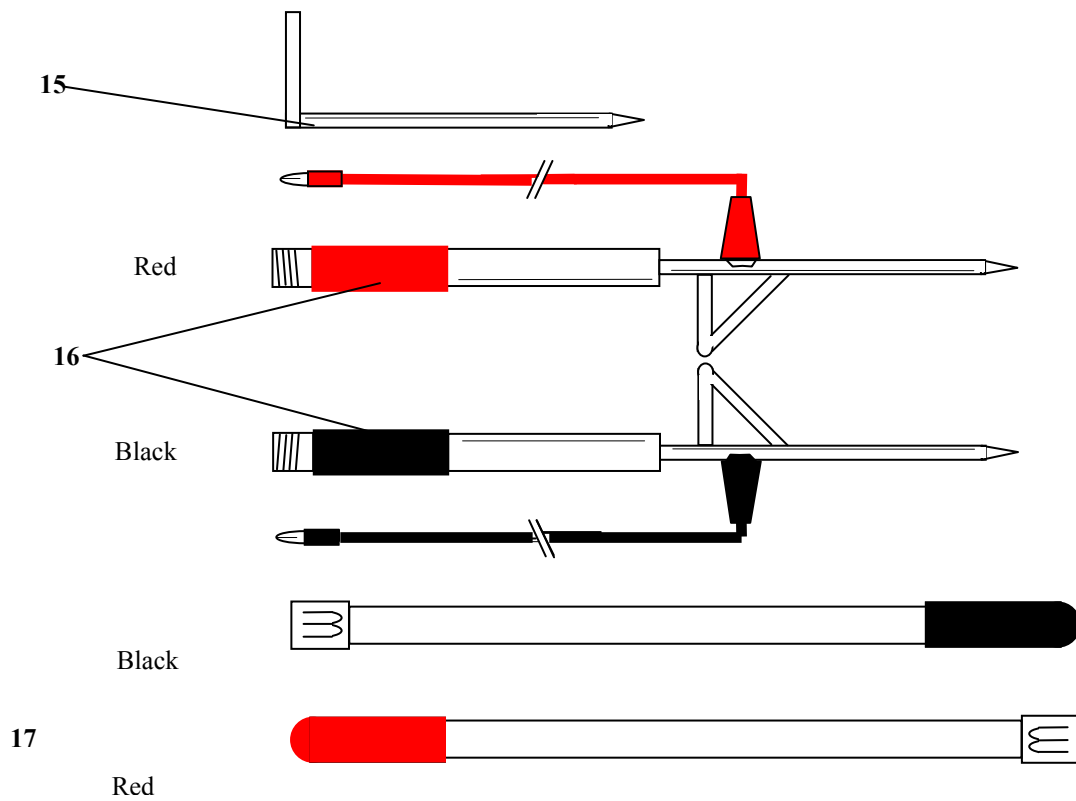

- 15. Transmitter ground probe. For use with black Transmitter output cable to establish ground connection.
- 16. Red & Black Detector probes with cables. These plug into the rear of Detector unit with attached banana jacks.
- 17. Red & Black Detector probe extenders / handles.

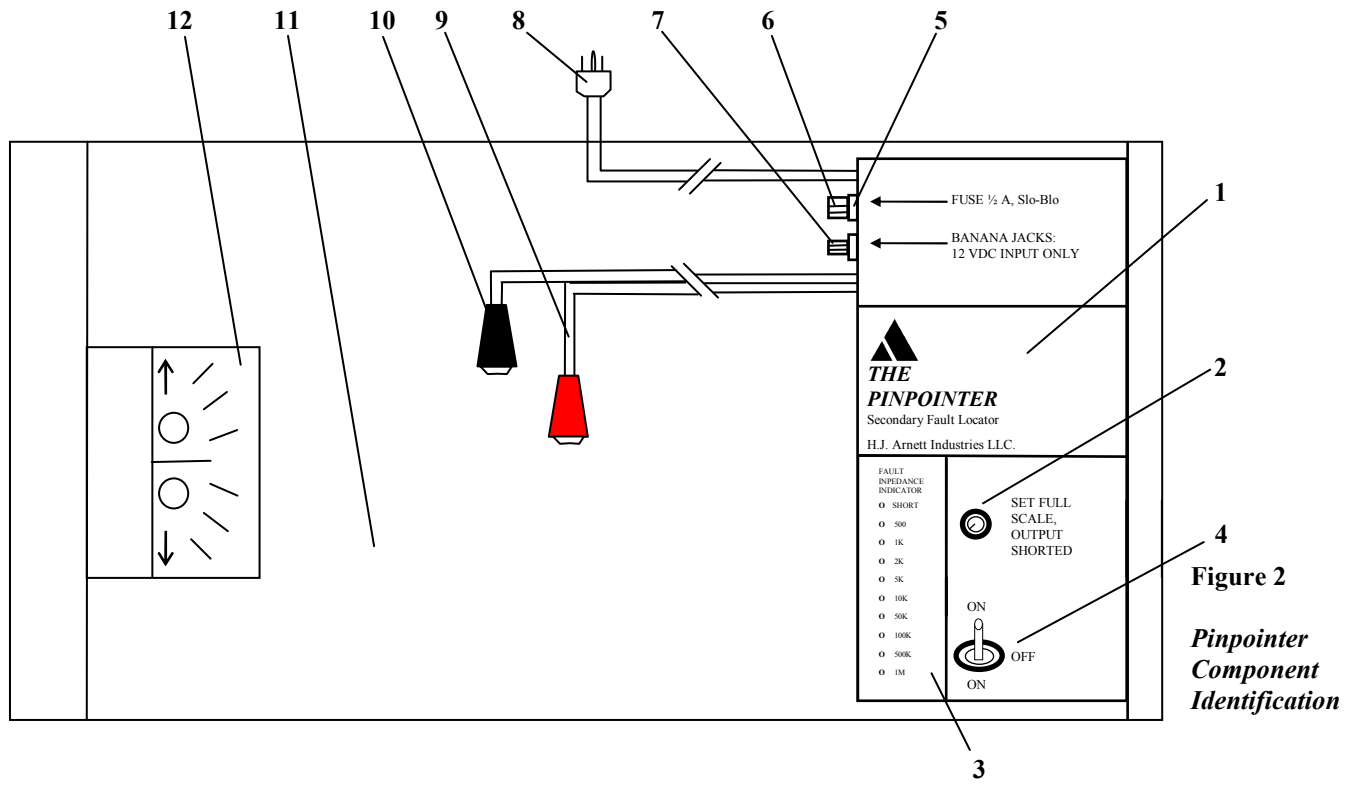

1. Transmitter module.
2. Zero adjust knob. It is used to calibrate the instrument.
3. Transmitter fault impedance indicator. As shown in figure 1, this series of L.E.D.s shows the Transmitter pulse, and can also indicate voltage on a faulted cable.
4. High voltage output on-off-on switch. Up "ON" is the AC Down "ON" is the battery..
5. 1/2 amp slow-blow fuse.
6. Negative (black) terminal for external 12-volt D.C. input source.
7. Positive (red) terminal for external 12-volt D.C. input source.
8. 120-volt, 60Hz A.C. power cord.
9. Red 12' high-voltage Transmitter output cable.
10. Black 12' Transmitter ground cable.
11. Cable storage area. (The optional rechargeable battery is mounted here).
12. Detector (in storage bracket).

Power is applied to the Transmitter from a number of sources. It can be plugged into a standard 120-volt, 60Hz A.C. outlet, or through the provided 120VAC adapter cord, can be connected at the house meter or the transformer. In the event that A.C. power is not available, a remote 12-volt D.C. source, such as a truck battery, can be used to power the Transmitter, using the provided 12VDC battery cable. The optional rechargeable battery kit fits inside the Pinpointer case, and includes a cable for local 12VDC operation.

C. The Detector

The 2500-volt pulse emitted by the Transmitter is detected on the surface of the ground using the Detector and Detector probes. The Detector is a super-sensitive galvanometer that uses the earth-gradient method for locating ground faults. The Detector uses the very latest solid-state electronics to operate an amplifier which drives a special quick-response, zero-centered, 3½" D.C. micro-ammeter. The large meter is the face of the Detector, while all operating controls are located at the rear and are recessed for operation in inclement weather.

The controls consist of a pull-on/push-off power switch combined with the zero balance control, a sensitivity adjust control, and a battery test push-button switch. A common 9-volt battery (Eveready #216 or equivalent) powers the Detector, which is housed in an attractive brushed aluminum shell. A strap allows the Detector to be suspended from the operator's neck for convenience.

D. Other Components

All components are housed in a sturdy steel case. The Transmitter module is bolted securely to the case, as is the optional rechargeable battery when ordered. All other parts are removable as shown in the following diagrams.

I. Description

A. General

The Pinpointer is an unshielded cable fault locator. It can find faults within inches on direct-buried cables, and in many cases can be used on primary (shielded) cables with great accuracy. The Pinpointer is a rugged, quality-built instrument designed to be easily transported and used by a single operator. It consists of two main functional parts:

- A) the Pinpointer Transmitter, which emits a high-voltage square wave pulse down the faulted cable, and
- B) the Pinpointer Detector, a super-sensitive galvanometer that directs the operator to the location of the fault.

The instrument is shipped as a complete unit, including the Transmitter, Detector, Detector probes and extenders, ground probe, 120VAC adapter cord, 12VDC battery cable, operation manual, and sturdy carrying case. An optional rechargeable battery kit is also available.

B. The Transmitter

The Transmitter emits a 2500-volt, square-wave pulse every 3 to 4 seconds. This pulse will burn through to ground any type of unshielded fault you may encounter. After the high-voltage pulse assures a burn-down to ground, the pulse amplitude drops and continues to drop until the cable fault is burned to its least impedance value. For example, the Transmitter will output only 50 volts at 80 milliamps into a fault with 625-ohms impedance.

The Transmitter has a built-in 2500-volt Megger that instantly shows the operator which cable is faulted and the approximate impedance of the fault (see figure 1). On a long unfaulted cable the first indicator light (1 Meg) might come on. This is an indication of charging current and not a sign of poor insulation.

Figure 1
Fault Impedance Indicator

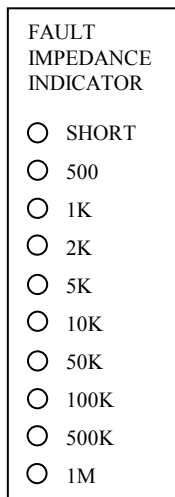

To order parts or for assistance, call or write:

H.J Arnett Industries, L.L.C.
20460 Avery Court
Tualatin, OR 97062

Phone (503) 692-4600 -- Fax (503) 692-4661

Warranty And Limitation

Parts and labor are guaranteed for one year from date of purchase. Any return is subject to a restocking charge and must be accompanied by a Return Authorization.

All statements, technical information and recommendations contained herein are based on tests we believe to be reliable, but the accuracy or completeness thereof is not guaranteed, and the following is made in lieu of all warranties, express or implied: Seller's and manufacturer's only obligation shall be to replace such quantity of the product proved to be defective. Neither seller nor manufacturer shall be liable for any injury, loss or damage, direct or consequential, arising out of the use of or the inability to use the product. Before using, user assumes all risk and liability whatsoever in connection therewith. No statement or recommendation not contained herein shall have any force or effect unless in an agreement signed by officers of seller or manufacturer.

The Pinpointer

An Unshielded Cable Fault Locator OPERATIONS MANUAL

Table of Contents		Page
I.	Description	3
	A. General	3
	B. The Transmitter	3
	C. The Detector	4
	D. Other Component	4
II.	Operation	
	A. General	8
	B. Transmitter Connections	8
	C. Calibrating the Fault Impedance Indicator	8
	D. Connecting to Faulted Cable & Ground	9
	E. Detector Connections	11
	F. Locating the Fault	11
	G. Locating a Fault at the Riser	13
III.	Theory of Operations	14
IV.	Optional Rechargeable Battery Kit Instructions	15
V.	Troubleshooting	16
VI.	Parts List	17
VII.	Specifications	18

Illustrations

Fig. 1	Fault Impedance Indicator	3
Fig. 2	Pinpointer Component Identification	5
Fig. 3	Power Cables	6
Fig. 4	Probes	6
Fig. 5	Detector	7
Fig. 6	Typical Pinpointer Connections	9
Fig. 7	Connection with Multiple Meters	10
Fig. 8	Meter Deflection Examples	12
Fig. 9	Confirming Location When Cable Route is Unknown	12
Fig. 10	Locating a Fault at Meter Riser	13
Fig. 11	Lines of Flux	13

The Pinpointer I

AN UNSHIELDED CABLE FAULT LOCATOR

Operations Manual



H.J. Arnett Industries, L.L.C.
20460 Avery Court



Tualatin, OR 97062



503-692-4600